

High Wall Heat Pump System

Location:	Approval:
Engineer:	Date:
Submitted to:	Construction:
Submitted by:	Unit #:
Reference:	Drawing #:

36,000 BTU R454B Basic Single Zone Ductless Mini Split Air Conditioner and Heat Pump w/WIFI (Package)

Package Model: BFMS3618BA-02

Indoor Model: BFMS36BA-02I

Outdoor Model: BFMS36BA-02O



EFFICIENCY

Cooling		Heating	
SEER2	19.5	HSPF2.4	9.1
EER2	9.3	COP	2.95

PERFORMANCE of Cooling

Cooling (Btu/hr)	
Rated Capacity	36000
Min/Max Capacity	6600~36800
Moisture Removal(L/h)	5.1
Standard Operating Range(*F/*C)	-13~122(-25~50)
Conditions:	Indoor: 80°F DB/67°F WB Outdoor: 95°F DB/75°F WB

PERFORMANCE of Heating

Heating (Btu/hr)	
1. @ 47°F Rated	36000
1. @ 47°F Min/Max Capacity	11400~44000
2. @ 17°F Rated	25600
3. @ 5°F Rated: Capacity / COP	24000/2.02
3. @ 5°F Max: Capacity	24000
Standard Operating Range(*F/*C)	-13~75(-25~24)
1. Conditions:	Indoor: 70°F DB/60°F WB Outdoor: 47°F DB/43°F WB
2. Conditions:	Indoor: 70°F DB/60°F WB Outdoor: 17°F DB/15°F WB
3. Conditions:	Indoor: 70°F DB/60°F WB Outdoor: 5°F DB/5°F WB

INDOOR SPECIFICATION

Indoor Air Flow (Turbo/H/M/L/Si) (CFM)	871.1 / 676.9 / 447.3 / 329.6 //	
Indoor Noise Level (Turbo/H/M/L/Si) (dBA)	57.0/51.0/45.0/33.5/27.5	
Dimension (W×D×H)	inch	49.57 x 11.14 x 14.25
	mm	1259.0×283.0×362.0
Package (W×D×H)	inch	52.76 x 17.72 x 15.16
	mm	1340×450×385
Net/Gross Weight	lbs	43.43/56.88
	kg	19.7/25.8

OUTDOOR SPECIFICATION

Compressor Type	ROTARY	
Compressor Model	KTF250D22UMT	
Refrigerant	R454B	
Refrigerant Oil Charge(mL)	670	
Refrigerant Oil	VG74	
Outdoor Air Flow (Max) (CFM)	2235.3	
Outdoor Noise Level (dBA)	63.0	
Dimension (W×D×H)	inch	37.24 x 16.14 x 31.89
	mm	946.0×410.0×810.0
Package (W×D×H)	inch	42.91 x 19.68 x 34.84
	mm	1090×500×885
Net/Gross Weight	lbs	150.35/160.27
	kg	68.2/72.7

ELECTRICAL

Power Supply	208/230V,60Hz,1Ph
System MCA	33.0
Connection Wiring	14#x4
System MOCP	35
Compressor RLA	21.5
Outdoor Fan Motor RLA	1.3
Outdoor Fan Motor W	120
Indoor Fan Motor RLA	1.0
Indoor Fan Motor W	58
System Power Input @ Cooling (W)	3830(735 ~ 4400)
System Power Input @ Heating (W)	3580(1015 ~4800)
MCA: Min. circuit amps (A)	MOCP: Max. over current protection (A)
RLA: Rated load amps (A)	W: Fan motor rated output (W)

PIPING

Throttle type(Indoor)	N/A
Throttle type(Outdoor)	EXV+Throttle valve
Liquid Size	9.52mm(3/8in)
Gas Size	15.9mm(5/8in)
Max. Piping Length(ft/m)	213.20(65)
Max. Height Difference(ft/m)	98.40(30)
Max. Pre-charged Length(ft/m)	24.6(7.5)
Refrigerant Pre-charged Amount(oz/g)	112.88(3.2)
Additional Charge of Refrigerant((oz/ft)/(g/m))	0.32(30)
Connection Method	Flared

Indoor Unit Dimension

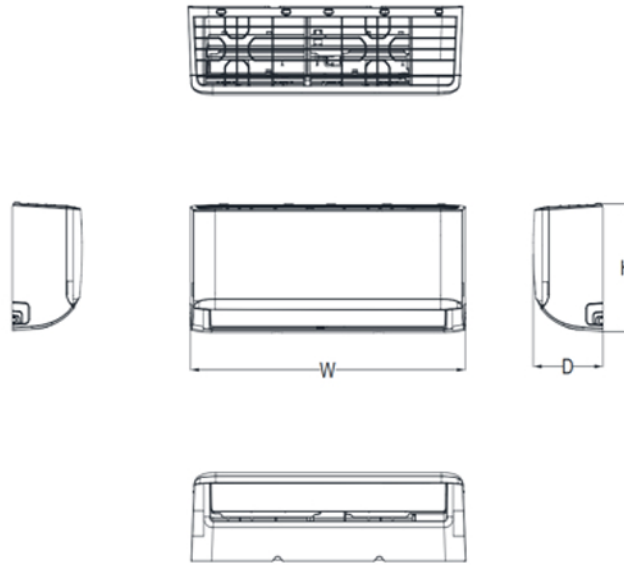

Capacity	Body Code	W(inch/mm)	D(mm/inch)	H(mm/inch)
6K~9K	A	28-3/4in /729mm	7-7/8in /200mm	11-1/2in /292mm
9K~12K	B	31-5/8in /802mm	7-7/8in /200mm	11-5/8in /295mm
18K	C	38-1/4in /971mm	9in/228mm	12-5/8in /321mm
18K~24K	D	42-5/8in /1082mm	9-1/4in/234mm	13-1/4in /337mm
30K~36K	F	49-5/8in /1259mm	11-1/8in/283mm	14-1/4in /362mm

Outdoor Unit Dimension

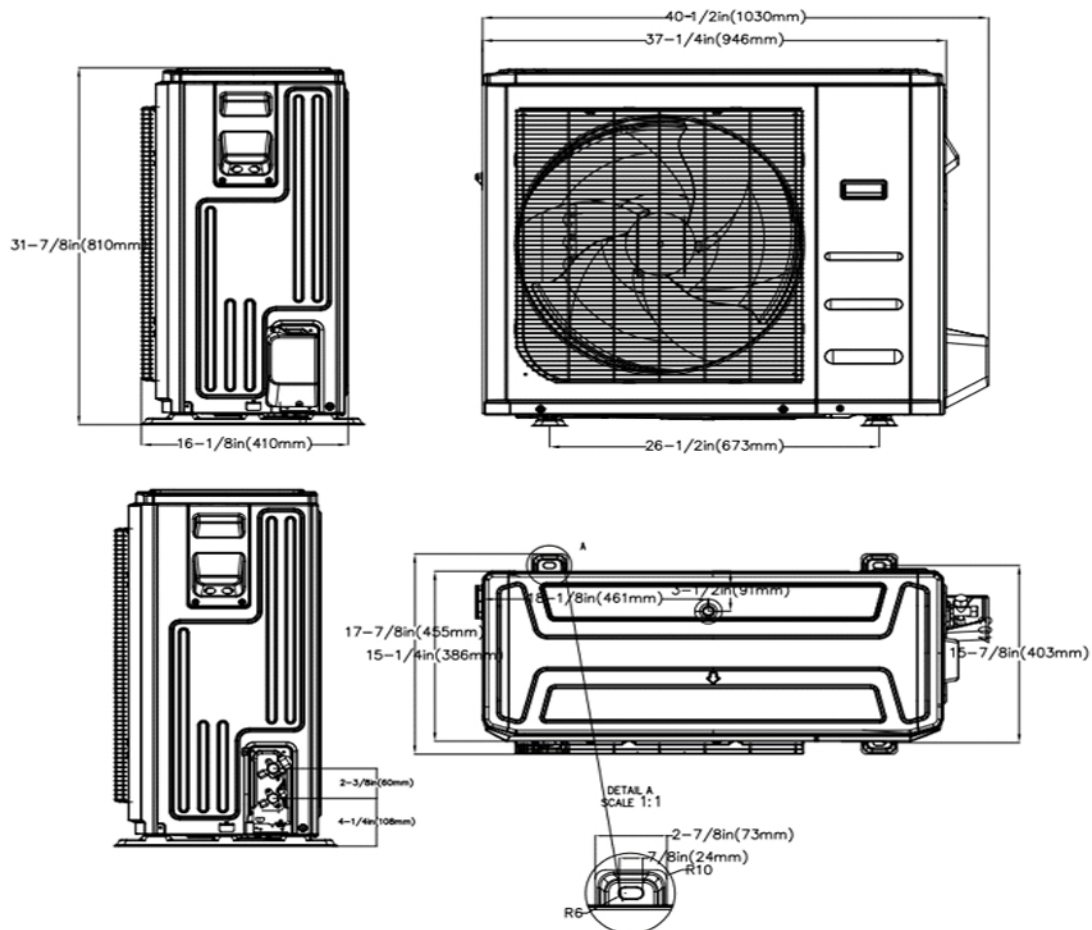

Installation Instruction

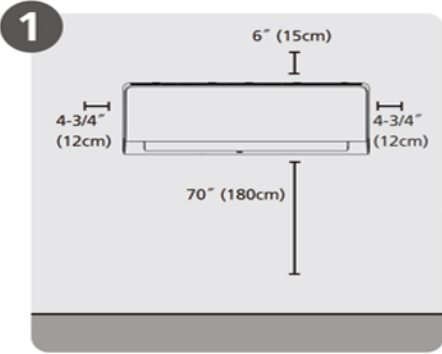

Select Installation Location

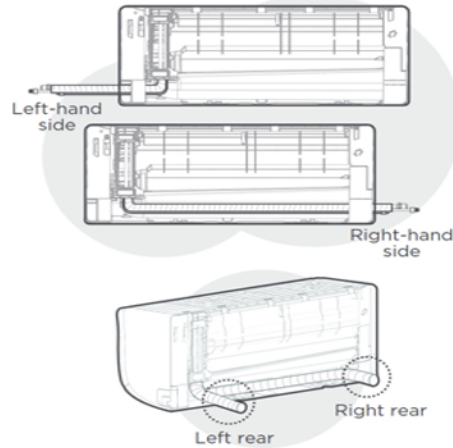

NOTE:
Based on the position of the wall hole relative to the mounting plate, choose the side from which the piping will exit the unit. You have four options for the exit direction of the

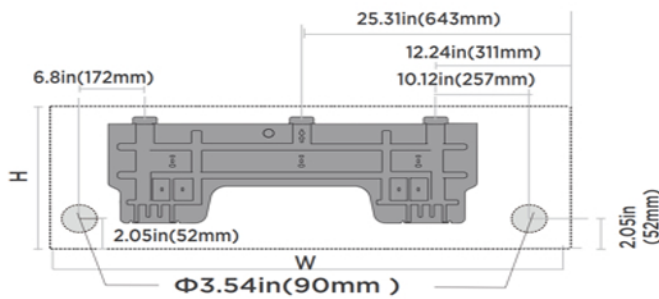

Indoor unit dimensions(WxH):
49.57in(1259mm)x14.25in(362mm)

NOTE:
When the gas side connective pipe is Φ (5/8in)16mm or more, the wall hole should be (3-1/2in)90mm.

Installation Instruction

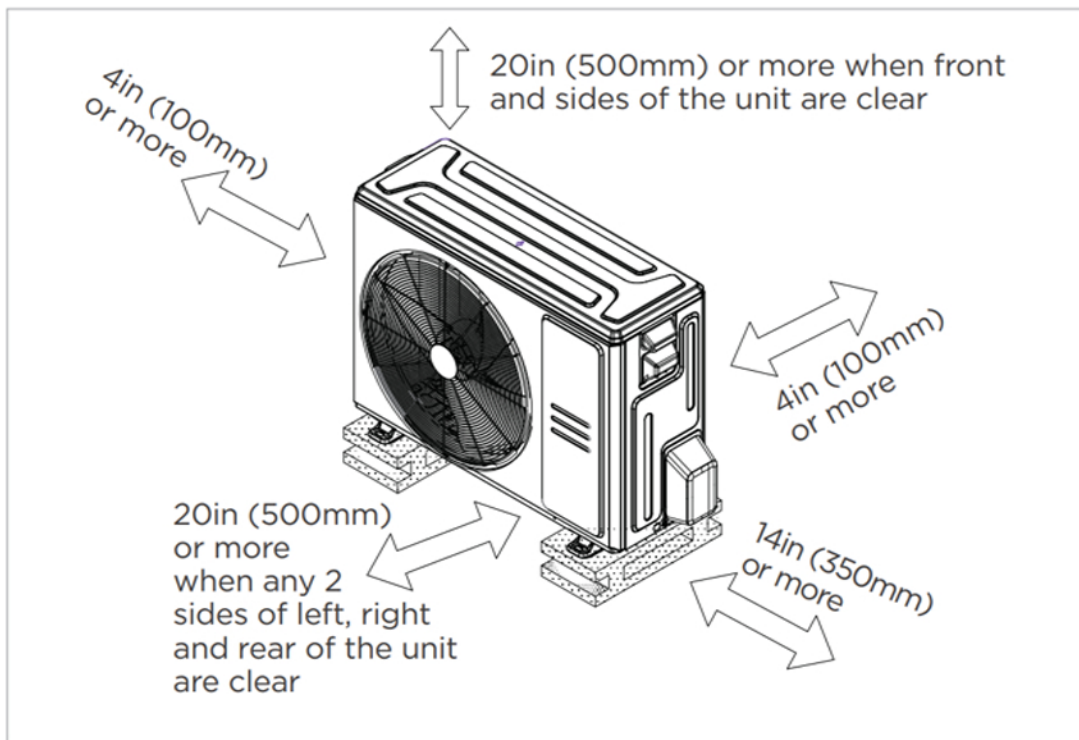

Meets all spatial requirements shown in Installation Clearance Requirements above.